

Magnetically triggered Child safety gate latch – Series 3



Industry leading
magnetic technology
that works first time
every time

 **LIFETIME
WARRANTY**

World's leading child safety gate latch

- Industry leading magnetic latching technology
- Improved child resistant design
- Meets Australian Safety Standards – AS1926.1-2012
- Visual indicator provides Locked/Unlocked status
- 6-pin lock for higher security
- Can be rekeyed (by locksmith) to match doors
- Vertical and horizontal adjustment
- Alignment marks indicate if adjustment required



D&D Technologies

World's most trusted gate hardware



Industry renowned safety features of the Series 3 model

For over 25 years the **MagnaLatch**® 'Top Pull' - the world's best-selling gate latch, has set the standard to keep toddlers safe around pools, homes, playgrounds and childcare centres. Now, the new **MagnaLatch**® 'Series 3' range offers even greater safety and security.

With its patented Lost-Motion Technology, the innovative magnetic action engages every time and stays shut, no matter how much it's pulled or shaken. For convenience, the key lock can now also be rekeyed to match your other locks, such as your front door. And the new visible Lock Indicator shows you at a glance whether it's locked or unlocked.

Easy to install and adjust for gate sag and ground shift, the new **MagnaLatch**® 'Series 3' Top Pull comes with a Lifetime Warranty and is available from good hardware stores and fencing contractors.

Product Dimensions

CODE	COLOUR	MODEL FEATURE	IDEAL GAP	GAP VARIANCE
ML3TPLA	Black	Top Pull 6-Pin Lock - Keyed Alike	19mm)	10-35mm
ML3SKLA	N/A	Replacement Lockwood Key (Australian)		



Safer, ergonomic lift knob

New design more conveniently shaped and child resistant than ever.



Visible Lock Indicator

Shows you, at-a-glance, whether latch is locked or unlocked. With 6-pin re-keyable lock cylinder to match existing locks around the home.



Product traceability

Superior Australian quality manufacturing and responsible product tracking with D&D's unique numbering system.

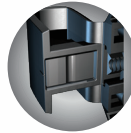

Permanent magnets are sealed

Quality tested to ensure ongoing performance and reliability, that will not fail with use or from environmental impact.



T-track innovation

Offers superior fixing strength and unsurpassed reliability.



Improved drainage in latch & striker

Sloping design channels water out of latch.



Vertical and horizontal alignment

Indicators on mounting brackets help identify when adjustment is required.



MagnaLatch® Series 3 Top Pull

NOTE: MagnaLatch® S3 models are keyed alike

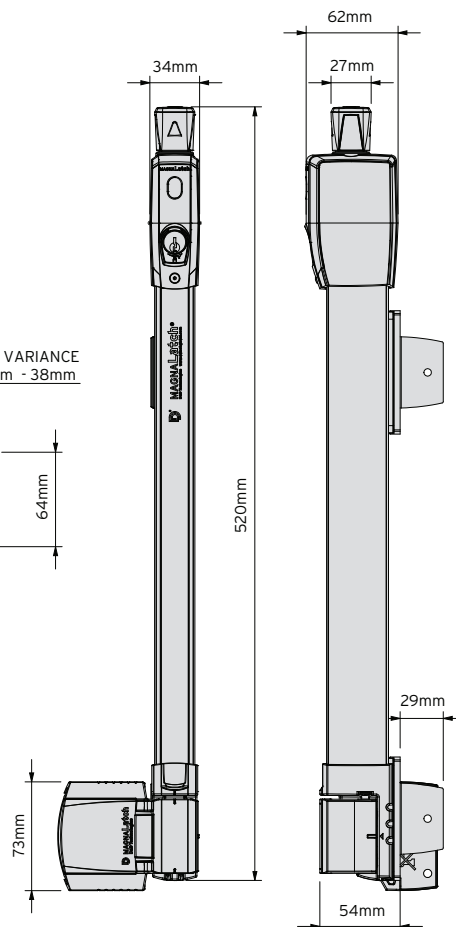
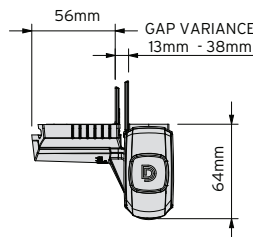

www.ddtechglobal.com

Unit 6, 4-6 Aquatic Drive, Frenchs Forest NSW 2086
Tel: (02) 9454 7888 Email: sales@ddtech.com.au